

Options for ABB drives, converters and inverters

User's manual

FAIO-01 analog I/O extension module



Power and productivity
for a better world™



List of related manuals

Drive manuals and guides

Code (EN/Multilingual)

<i>ACS880-01 manuals</i>	9AKK105408A7004
<i>ACS880-04 manuals</i>	9AKK105713A4819
<i>ACS880-07 manuals</i>	9AKK105408A8149

Option manuals and guides

<i>FAIO-01 analog I/O extension module user's manual</i>	3AUA0000124968
--	--------------------------------

You can find manuals and other product documents in PDF format on the Internet. See section [Document library on the Internet](#) on the inside of the back cover. For manuals not available in the Document library, contact your local ABB representative.

User's manual

FAIO-01 analog I/O extension module

Table of contents



1. Safety instructions



4. Mechanical installation



5. Electrical installation



6. Start-up



Table of contents

1. Safety instructions

Contents of this chapter	9
Use of warnings	10
Safety in installation	11

2. Introduction to the manual

Contents of this chapter	13
Target audience	13
Contents	14
Terms and abbreviations	14

3. Hardware description

Contents of this chapter	15
Product overview	15
Layout	16
Input modes	17
Input signal types	17



4. Mechanical installation

Contents of this chapter	19
Necessary tools and instructions	19
Unpacking and examining the delivery	19
Installing the module	20
...onto the drive control unit	20
...onto an extension adapter module	21

5. Electrical installation

Contents of this chapter	23
Warnings	23
Necessary tools and instructions	23
Selecting the input mode, voltage range and signal type	24

Terminal designations 26
 Analog inputs 26
 Analog outputs 26
General cabling instructions 26
Wiring 27
 Connection example for motor winding temperature
 measurement 27
 Connection example for external devices 28

6. Start-up

Contents of this chapter 29
Before you start 29
Setting the parameters 30
 Example – Primary control program 30



7. Diagnostics

Contents of this chapter 33
Faults and warning messages 33
LEDs 33

8. Technical data

Contents of this chapter 35
Dimension drawing 36
Data 37
 Installation 37
 Degree of protection 37
 Ambient conditions 37
 Package 37
 Hardware settings 37
 A/D conversion resolution 37
 Isolation areas 38
 Analog inputs (XAI1:+1...-2, XAI2:+3...-4) 38
 Analog outputs (XAO1:+5...-6, XAO2:+7...-8) 39
 Power supply 39
 General 39

Further information

Product and service inquiries 41
Product training 41
Providing feedback on ABB Drives manuals 41
Document library on the Internet 41



8 *Table of contents*



1

Safety instructions

Contents of this chapter

The chapter contains the warning symbols used in this manual and the safety instructions which you must obey when you install or connect an optional module to a drive, converter or inverter. If you ignore the safety instructions, injury, death or damage can occur. Read this chapter before you start the installation.



Use of warnings

Warnings tell you about conditions which can cause injury or death, or damage to the equipment. They also tell you how to prevent the danger. The manual uses these warning symbols:



Electricity warning tells you about hazards from electricity which can cause injury or death, or damage to the equipment.



General warning tells you about conditions, other than those caused by electricity, which can cause injury or death, or damage to the equipment.



Safety in installation

These instructions are for all who install or connect an optional module to a drive, converter or inverter and need to open its front cover or door to do the work.



WARNING! Obey these instructions. If you ignore them, injury or death, or damage to the equipment can occur.

- If you are not a qualified electrician, do not do installation or maintenance work.
- Disconnect the drive, converter or inverter from all possible power sources. After you have disconnected the drive, converter or inverter, always wait for 5 minutes to let the intermediate circuit capacitors discharge before you continue.
- Disconnect all dangerous voltages connected to other connectors or parts in reach. For example, it is possible that 230 V AC is connected from outside to a relay output of the drive, converter or inverter.
- Always use a multimeter to make sure that there are no parts under voltage in reach. The impedance of the multimeter must be at least 1 Mohm.



12 Safety instructions





Introduction to the manual

Contents of this chapter

This chapter introduces this manual.

Target audience

This manual is intended for people who plan the installation, install, start up, use and service the extension module. Before you do work on the module, read this manual and the applicable drive, converter or inverter manual that contains the hardware and safety instructions for the product in question.

You are expected to know the fundamentals of electricity, wiring, electrical components and electrical schematic symbols.

The manual is written for readers worldwide. Both SI and imperial units are shown.

Contents

The manual consists of these chapters:

- **Safety** contains the safety instructions which you must obey when you install an extension module.
- **Hardware description** gives a short description of the extension module.
- **Mechanical installation** contains a delivery checklist and instructions on installing the extension module.
- **Electrical installation** contains instructions on selecting the input mode and signal type, and wiring the extension module.
- **Start-up** contains instructions on starting up the extension module.
- **Diagnostics** shows how to trace faults with the status LED on the extension module.
- **Technical data** contains the technical data of the extension module.

Terms and abbreviations

Term/abbreviation	Explanation
EMC	Electromagnetic compatibility

Later in this manual, term *drive* substitutes for string drive/converter/inverter.

3

Hardware description

Contents of this chapter

This chapter gives a short description of the extension module.

Product overview

The FAIO-01 analog I/O extension module expands the analog inputs and outputs of the drive control unit. It has two bipolar/unipolar current/voltage inputs and two unipolar current outputs.

FAIO-01 has basic insulation against the drive control unit ground, but together with basic-insulated motor temperature sensors, FAIO-01 forms double insulation. This allows you to measure, for example, motor winding temperature without a double or reinforced insulation requirement on the measuring element.

The extension module makes the signal and power connection to the drive through a 20-pin connector.

Layout

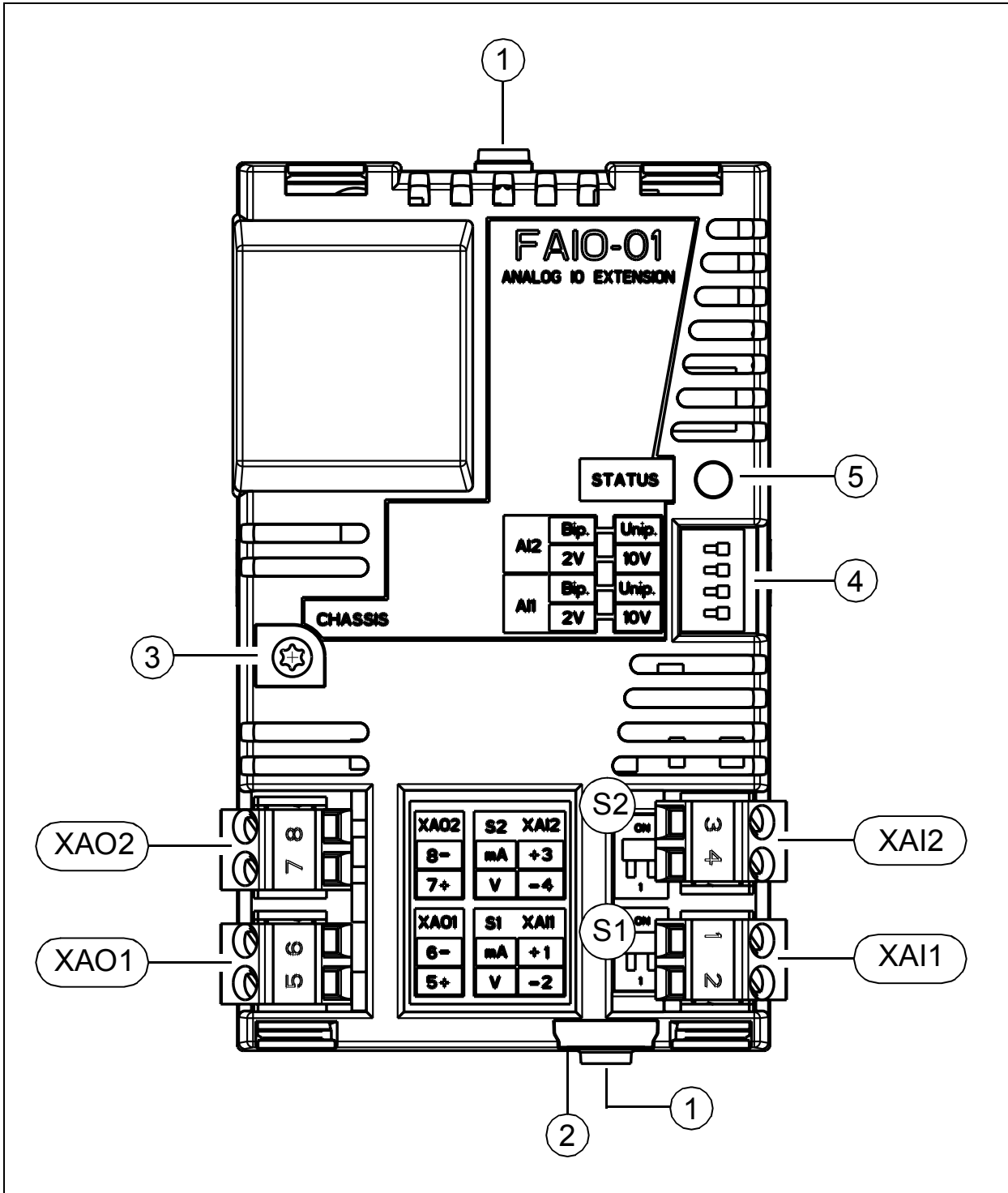

Item	Description	Additional information
1	Retaining clips	Page 19
2	Lock	
3	Mounting screw	
4	DIP switches for input mode and voltage range selection	Page 17 , 24
S1	DIP switch for XAI1 input signal type selection	Page 17 , 26
S2	DIP switch for XAI2 input signal type selection	
XAI1	2-pin detachable terminal blocks for analog inputs	Page 23
XAI2		
XAO1	2-pin detachable terminal blocks for analog outputs	Page 23
XAO2		
5	Diagnostic LED	Page 33

Input modes

The analog inputs can operate in two modes: bipolar and unipolar.

In the bipolar mode, the inputs can handle positive and negative signals. The way the drive interprets the negative range of the inputs depends on the settings of the drive. See the drive firmware manual.

In the unipolar mode, the inputs can handle positive signals only.

You can select the input mode with a DIP switch. The voltage range of the inputs is selected with the same switch.

Input signal types

The analog inputs can operate with a current or voltage signal. You can select the signal type with a DIP switch.

4

Mechanical installation

Contents of this chapter

This chapter contains a delivery checklist and instructions on installing the extension module.

Necessary tools and instructions

See the applicable drive hardware manual.



Unpacking and examining the delivery

1. Open the option package.
 2. Make sure that the package contains:
 - FAIO-01 analog I/O extension module
 - this manual.
 3. Make sure that there are no signs of damage.
-

Installing the module



WARNING! Obey the safety instructions. See chapter [Safety instructions](#) on page 9. If you ignore the safety instructions, injury or death can occur.

■ ...onto the drive control unit

1. Pull out the lock.
2. Put the module carefully into its position on the drive until the retaining clips lock it into position.
3. Push in the lock.
4. Tighten the screw to 0.8 N·m.

Note: The screw tightens the connections and grounds the module. It is necessary for fulfilling the EMC requirements and for proper operation of the module.



WARNING! Do not tighten the screw tighter than 0.8 N·m. Too big a torque value breaks the thread.

See the applicable drive manual for further instructions on how to install the module to the drive.

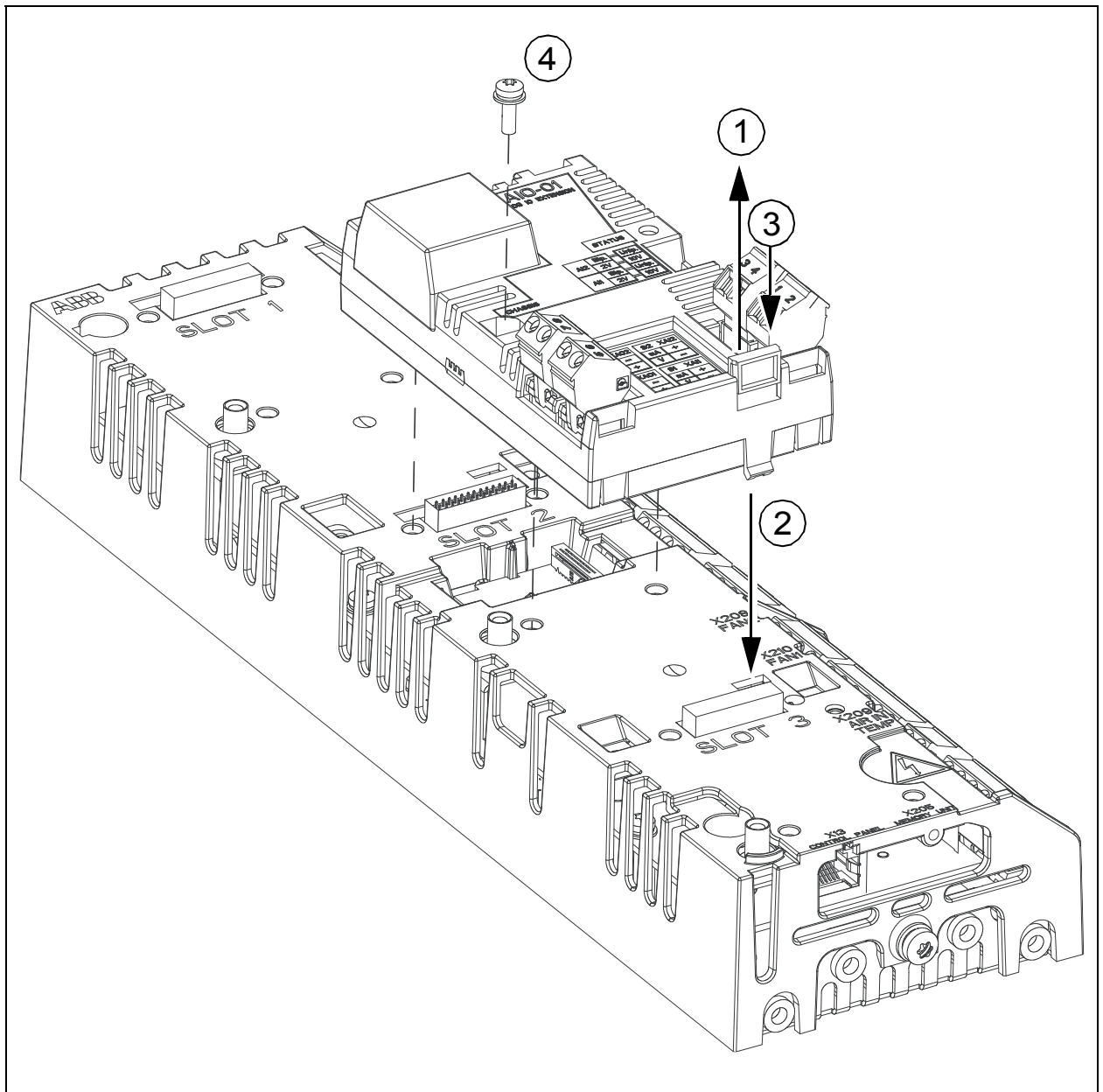

■ ...onto an extension adapter module

For instructions on how to install the module onto an extension adapter module, see *FEA-03 extension adapter module user's manual* (3AUA0000115811 [English]).



5

Electrical installation

Contents of this chapter

This chapter contains instructions on:

- selecting the input mode, voltage range and signal type
- wiring the extension module.

Warnings



WARNING! Obey the safety instructions. See chapter [Safety instructions](#) on page 9. If you ignore the safety instructions, injury or death can occur. If you are not a qualified electrician, do not do electrical work.



Necessary tools and instructions

See the applicable drive hardware manual.

Selecting the input mode, voltage range and signal type

Set the necessary DIP switches (see page 16) to applicable positions. Use a small screwdriver.

This table shows the possible selections for both digital inputs.

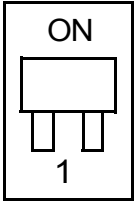
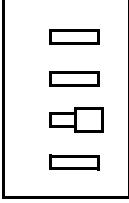
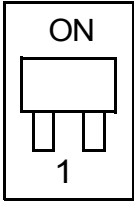
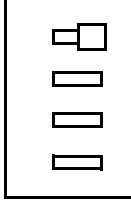
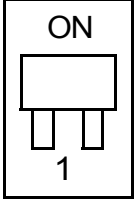
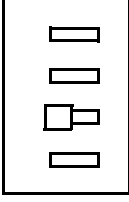
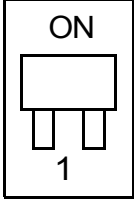
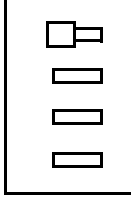
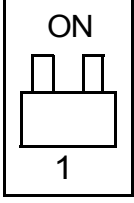
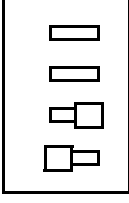
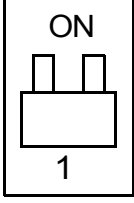
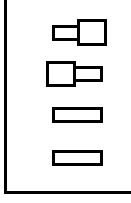
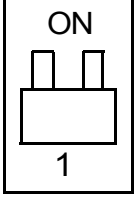
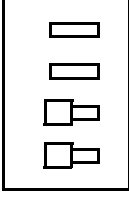
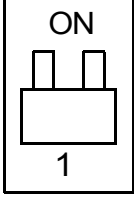
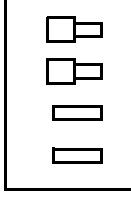
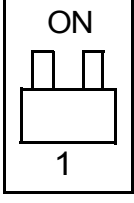
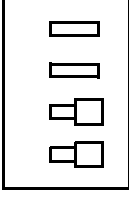
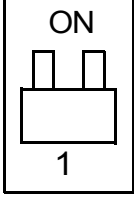
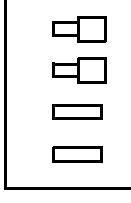
Selection	XAI1		XAI2	
	Switch S1	Input mode and voltage range ¹⁾	Switch S2	Input mode and voltage range ¹⁾
0...20 mA (default)				
±0...20 mA				
0...2 V				
±0...2 V				
0...10 V				

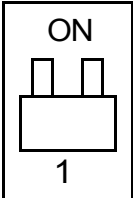
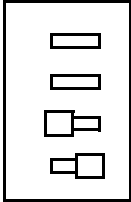
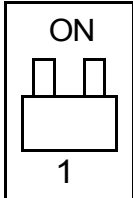
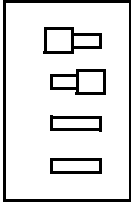

Selection	XAI1		XAI2	
	Switch S1	Input mode and voltage range ¹⁾	Switch S2	Input mode and voltage range ¹⁾
±0...10 V				

¹⁾ The voltage range switches are not in use when the corresponding input is operating in the current mode.



Terminal designations

■ Analog inputs

Marking		Description
XAI1		
1	+1	Analog input 1 positive terminal
2	-2	Analog input 1 negative terminal
XAI2		
3	+3	Analog input 2 positive terminal
4	-4	Analog input 2 negative terminal

■ Analog outputs

Marking		Description
XAO1		
5	+5	Analog output 1 positive terminal
6	-6	Analog output 1 negative terminal
XAO2		
7	+7	Analog output 2 positive terminal
8	-8	Analog output 2 negative terminal

General cabling instructions

Use 0.5...2.5 mm² twisted pair unshielded cable with an applicable voltage rating.

Do not route signal cables parallel to power cables.



Wiring

Connect the external control cables to the applicable module terminals.

■ Connection example for motor winding temperature measurement

This example shows how to connect three Pt100 sensors for motor temperature measurement between the analog inputs and outputs.

Do not connect both ends of the cable shields directly to ground. If a capacitor cannot be used at one end, leave that end of the shield unconnected.

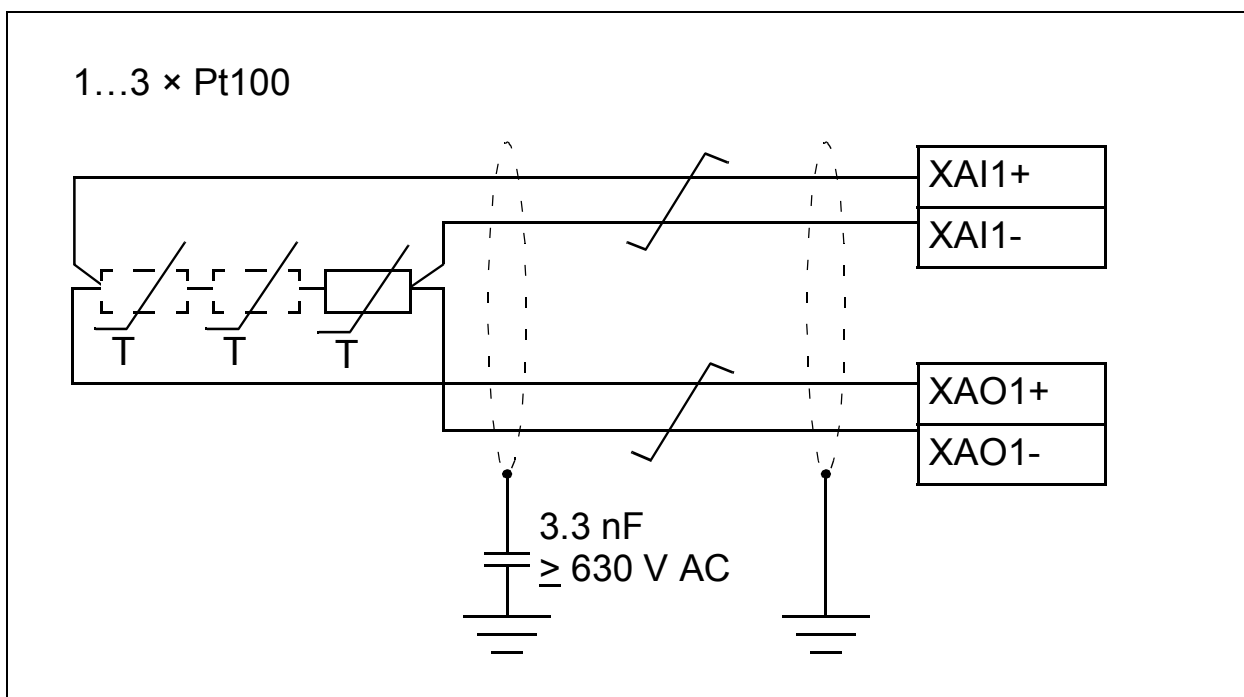

■ Connection example for external devices

This example shows how to connect transducers to the analog inputs and indicators to the analog outputs.

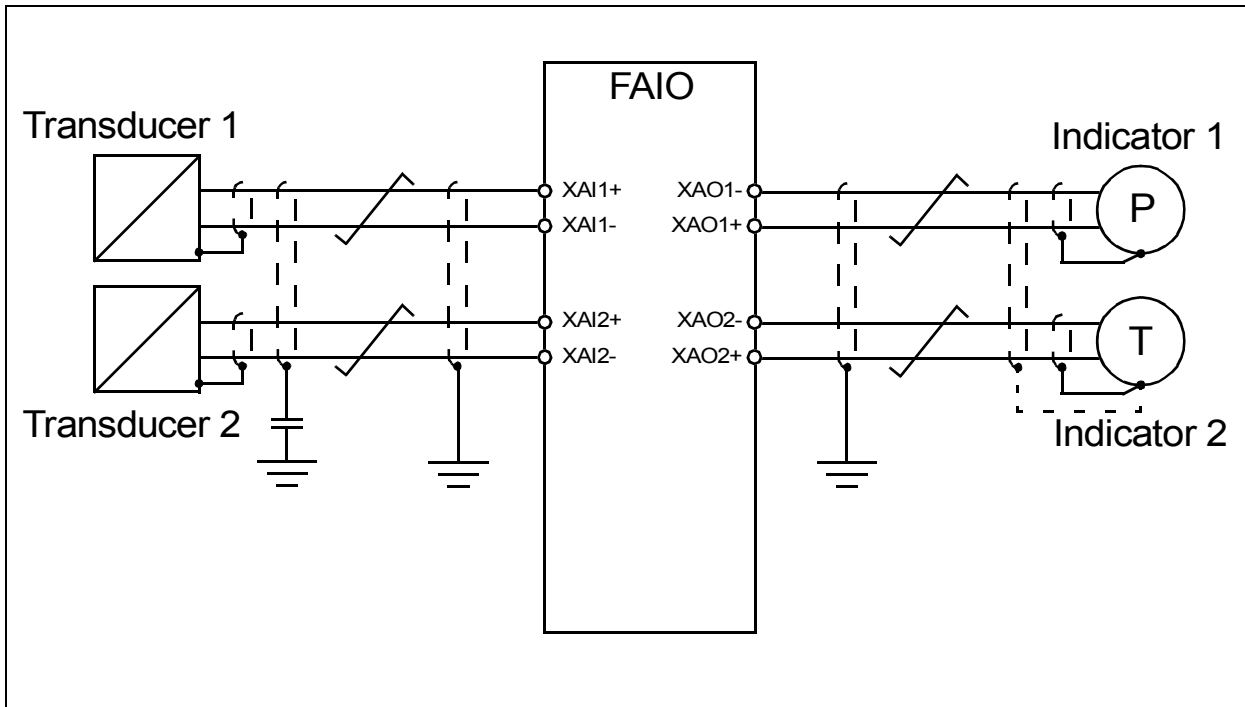

6

Start-up

Contents of this chapter

This chapter contains instructions on starting up the extension module.

Before you start

1. Make sure that you have set the DIP switches to applicable positions.
See section [Selecting the input mode, voltage range and signal type](#) on page 24.
2. Make sure that you have completed these start-up tasks for the drive:
 - Checks and settings with no voltage connected
 - Powering up the drive
 - Setting up the drive control program.See the applicable drive hardware manual.



Setting the parameters

The extension module is started up through drive parameters. For example, in ACS880 Primary control program the parameters for I/O extension modules are located in parameter groups 14...16. For other programs, see the applicable firmware manual.

■ Example – Primary control program

1. Power up the drive.
2. Specify the slot into which the extension module is installed on the drive control unit (**14.02 Module 1 location**).
3. Activate the communication between the extension module and the drive (**14.01 Module 1 type**).

You can now see the parameters of the extension module in group 14.

4. Make sure that the drive finds the correct extension module (**14.03 Module 1 status**).
5. Set the parameters of the extension module to applicable values.

The settings must correspond to the DIP switch settings and the wiring of the extension module.



6. If you want to use an input of the extension module as a signal source, choose the setting *Other* in the source selector parameter, and then specify the applicable value parameter in group 14.

Example: To connect supervision 1 to AI1 of the extension module:

- Select the mode of the supervision function (**32.05 Supervision function 1**).
 - Set limits for the supervision function (**32.09 Supervision 1 low** and **32.10 Supervision 1 high**).
 - Select the supervision action (**32.06 Supervision 1 action**).
 - Connect **32.07 Supervision 1 signal** to **14.27 AI1 scaled value** (14.27).
7. Set the rest of the required drive parameters to applicable values.

For more detailed information on the parameters, see the drive firmware manual.







Diagnostics

Contents of this chapter

This chapter shows how to trace faults with the status LEDs on the extension module.

Faults and warning messages

For the fault and warning messages concerning the extension module, see the drive firmware manual.

LEDs

The extension module has one diagnostic LED.

Color	Description
Green	The extension module is powered up.
Red	There is no communication with the drive control board or the extension module has detected some other error.



Technical data

Contents of this chapter

This chapter contains the technical data of the extension module.

Dimension drawing

The dimensions are in millimeters.

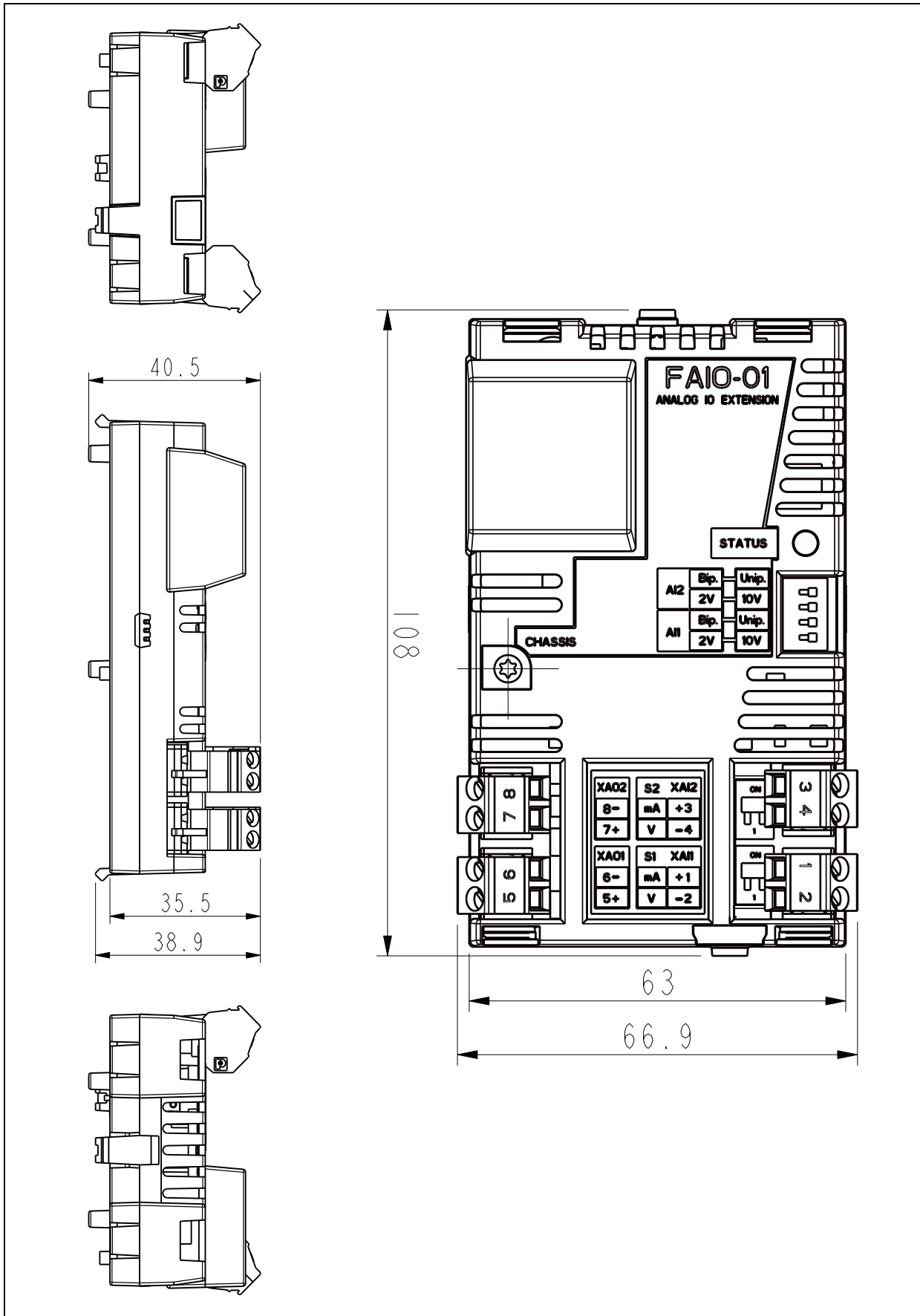

Data

■ Installation

Into an option slot on the drive control unit or onto an extension adapter module (FEA-03)

■ Degree of protection

IP20

■ Ambient conditions

The applicable ambient conditions specified for the drive in its manuals are in effect.

■ Package

Cardboard. Plastic wrapping: Antistatic air bubble sheet (PE).

■ Hardware settings

- One DIP switch per input for selection between unipolar mode (default) and bipolar mode
- One DIP switch per input for input voltage range selection
- One DIP switch (S1 and S2) per input for selection between current signal (default) or voltage signal

■ A/D conversion resolution

- Bipolar mode: 15 data bits (+ 1 sign bit)
 - Unipolar mode: 16 data bits
-

■ Isolation areas



Symbol	Description
—	Basic insulation (IEC 61800-5-1:2007)
- - -	Functional insulation (IEC 61800-5-1:2007)

■ Analog inputs (XAI1:+1...-2, XAI2:+3...-4)

- Connector pitch 5 mm, wire size max. 2.5 mm²
- Input ranges: (-20) 0...20 mA (default), (-2) 0...2 V, (-10) 0...10 V
- Input impedance: 100 ohm (current), ≥ 200 ohm (voltage)
- Inaccuracy: $\pm 0.2\%$ of input and $\pm 0.1\%$ of Full Scale Range at 25 °C
- Inaccuracy for Pt100 sensors: 5 °C (9 F)
- Basic insulation against the control unit ground (earth); functional insulation against the analog outputs
- Common mode rejection rating (CMRR): ± 15 V
- Hardware filtering time constant: 0.2 ms

■ Analog outputs (XAO1:+5...-6, XAO2:+7...-8)

- Connector pitch 5 mm, wire size max. 2.5 mm²
- Output range: 0...20 mA
- Load resistance max.: 700 ohm
- Inaccuracy: $\pm 0.2\%$ of output and $\pm 0.1\%$ of Full Scale Range at 25 °C
- Basic insulation against the control unit ground (earth); functional insulation against the analog inputs

■ Power supply

- +3.3 V and 24 V (supplied by the drive control unit or the FEA-03 extension adapter module)
- Max. power consumption: 50 mA at 3.3 V, 0.3 A at 24 V

■ General

- Complies with standards EN 61800-3, EN 61800-5-1, UL508C
 - cULus listed
 - Printed circuit board conformal coated
-

Further information

Product and service inquiries

Address any inquiries about the product to your local ABB representative, quoting the type designation and serial number of the unit in question. A listing of ABB sales, support and service contacts can be found by navigating to www.abb.com/searchchannels.

Product training

For information on ABB product training, navigate to www.abb.com/drives and select *Training courses*.

Providing feedback on ABB Drives manuals

Your comments on our manuals are welcome. Go to www.abb.com/drives and select *Document Library – Manuals feedback form (LV AC drives)*.

Document library on the Internet

You can find manuals and other product documents in PDF format on the Internet. Go to www.abb.com/drives and select *Document Library*. You can browse the library or enter selection criteria, for example a document code, in the search field.

Contact us

www.abb.com/drives

www.abb.com/solar

www.abb.com/windpower

www.abb.com/drivespartners

3AUA0000124968 Rev B (EN) 2014-09-10

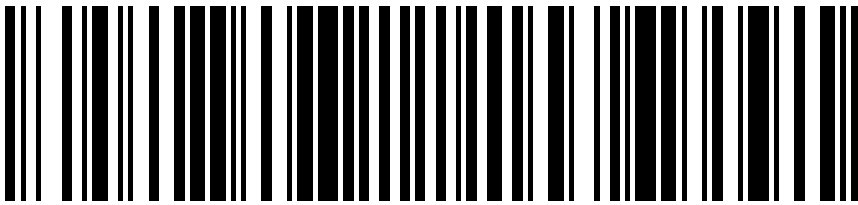

3AUA0000124968B

Power and productivity
for a better world™

