

## Demag DR rope hoists

Versatile and fast – for load capacities up to 50 t



## Demag Cranes & Components – leading the way with innovative solutions

Efficiency and high operating reliability are clearly defined requirements to be met by state-of-the-art material flow, logistics and drive solutions. Demag Cranes & Components develops and manufactures innovative products for industrial drives, load handling and material flow applications for a wide variety of production and storage solutions. Products that guarantee minimised maintenance requirements thanks to low wear.

With expertise for materials handling components, cranes and hoists gained from almost 200 years of experience, Demag Cranes & Components supplies efficient product solutions and services to companies in all industries and to customers of all sizes. Demag Cranes & Components places priority on meeting customer needs, so that its products and services can be seamlessly integrated into the customer's value creation process.



# Demag DR rope hoists – high performance for tomorrow's needs

Demag DR rope hoists meet all the requirements of state-of-the-art hoist units and give you the certainty of a secure long-term investment. Besides their particularly long service life, they also offer comprehensive standard features at an attractive price.

## Higher hoist speed for faster handling

Most Demag DR rope hoist models have a lifting speed of at least 6 m/min with 4/1 reeving as standard.

## Higher availability for greater efficiency

DR rope hoists are supplied with an increased FEM classification. The rope drive mechanism precisely meets FEM specifications, however, the gearbox service life is 20 percent longer. This means that there is 20 percent more time until the general overhaul is due when the safe working period has elapsed. The generous dimensioning of all components also ensures constant availability.

The modular rope hoist design facilitates simple and rapid maintenance and repair of individual components, thus cutting any downtime to a minimum.

In addition to the economic benefits, Demag DR rope hoists also provide a high level of safety for the operator and the load.

## Outstanding versatility

Available in four basic designs, the right solution can be found for virtually any application with Demag DR rope hoists:

- GDR basic hoist
- FDR foot-mounted hoist
- EKDR monorail hoist
- ZKDR double-rail crab



Demag rope hoists move helicopters into position for maintenance.

## Safety and efficiency down to the last detail

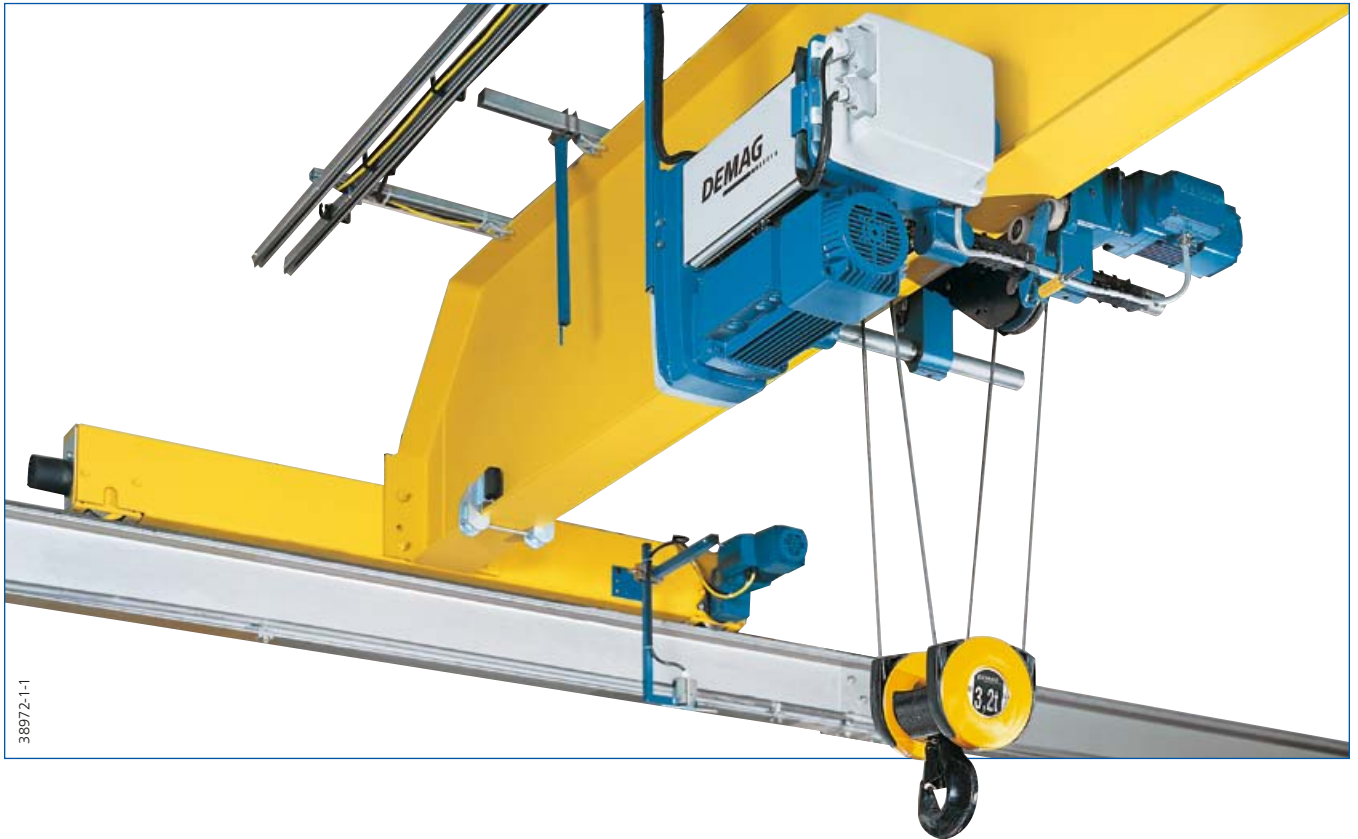

### Low-vibration motor for quiet operation

- Optimised motor design for low-vibration, quiet operation
- 12/2-pole or 4-pole squirrel-cage motor with cylindrical rotor
- Thermal contacts to protect against overheating as standard
- IP 55 enclosure
- Pulse encoder to monitor the speed and direction of rotation as standard
- Duty factor higher than FEM classification

### Fast acting brake

- Demag DC disk brake with brake release monitoring, minimum brake safety factor of 1.8
- Fast acting brake thanks to integrated electronic modules

### Gearbox lubricated for life

- Three-stage helical gearbox with high endurance gearing and oil lubrication for the entire service life

### Protective rope guide

- Rope guide made of tough plastic – reliable operation even in critical environments
- Smooth rope lead-in by means of hardened pressure rollers mounted on anti-friction bearings
- Inclined pull up to 4° without touching the rope guide

### User-friendly bottom block

- Guard for improved safety – moving plastic elements protect the opening where the wire rope enters the bottom block
- Two handle recesses make it easier to handle and guide the bottom block

### State-of-the-art electrical equipment

- Reliable internal signal transmission
- Electrical equipment completely of modular design
- Electrical enclosure with IP 55 protection
- Load spectrum recorder integrated in the controls to determine the remaining safe working period

### Precision geared limit switch

- Automatic cut-off of the lifting and lowering motions in the limit positions
- Four contacts set for emergency cut-off in the upper and lower positions as standard
- Additional safety thanks to fast-to-slow cut-off
- Other functions, e.g. an operating limit switch, can also be set

### Overload protection

- Electro-mechanical overload protection integrated in the rope retaining crosshead
- Evaluation by means of the central electronic unit which also specifies the partial load switching point for a measuring run at slow lifting speed
- Optional: electronic overload protection for summation when several hoists are used, load display and slack rope cut-off

### Ergonomically optimised controls

- Cable-connected Demag DSE-10R control pendant
  - For two-stage and stepless operation
  - Control cable available in three lengths, each infinitely adjustable in length by 4 m or with 2 TY cable for extremely arduous applications
  - Load display for use with electronic overload protection
- Demag DRC-10 radio control
  - Tough hand-held transmitter with proportional push-buttons
  - Frequency hopping for reliable radio signal transmission
  - Bi-directional signal transmission
  - Intelligent charging system
- Both control pendant switches fitted with a display for the load range and specific installation status information
- IrDA interface for direct data transfer with a laptop or PDA



# GDR basic hoist – the optimum solution for plant engineering



- For individual installation in any design
- Four different mounting positions and four rope lead-off variants for versatile solutions
- Rope guide can be used for every rope lead-off position
- Can be attached on three sides (two attachment arrangements for size GDR 20)
- Additional electrical enclosure can be fitted to the hoist frame
- Load capacities up to 50 t



Load elevator precisely positioned by a Demag GDR basic hoist.

Attachment variants and rope lead-offs

39821-2
39823-2
39820-2
39822-2

Load bar operation

## FDR foot hoist – the solution ready for installation in cranes

- Reeving parts for all common reeving arrangements are fitted to the hoist unit – enabling foot hoists to be integrated direct into prepared steel structures or special crabs
- Can be used in two mounting positions, each with one rope lead-off direction
- Can be attached on three sides
- Load capacities up to 50 t



Demag FDR foot hoists travelling on a semi-automatic circuit in a galvanising plant.

## EKDR monorail hoist – the series travelling hoist for single-girder cranes



- Compact design with optimum approach dimensions
- Infinitely-variable cross-travel speeds for low sway and gentle positioning
- Cross-travel inverter and braking resistor integrated in the electrical enclosure to save space
- Load capacities up to 12.5 t



Two EKDR monorail hoists transporting aluminium profile sections in tandem operation.



## EZDR double-rail crab – the series hoist for double-girder cranes



- Features as for EKDR monorail hoists
- 1,400/2,240/2,800 mm standard track dimensions, other track gauge dimensions possible
- Anti-derailment and lift-off protection for improved safety as standard
- Load capacities up to 50 t



39804-52

39472

# Demag Service – always ready to help

Demag Cranes & Components offers you comprehensive and reliable service with its world-wide network of Demag expert service teams and Demag partners. They ensure the maximum possible availability and safety in your installation.

## Rapid and reliable spare part supply

Customers all over the world are supplied with the required spare parts quickly and flexibly by Demag Cranes & Components and its service network.

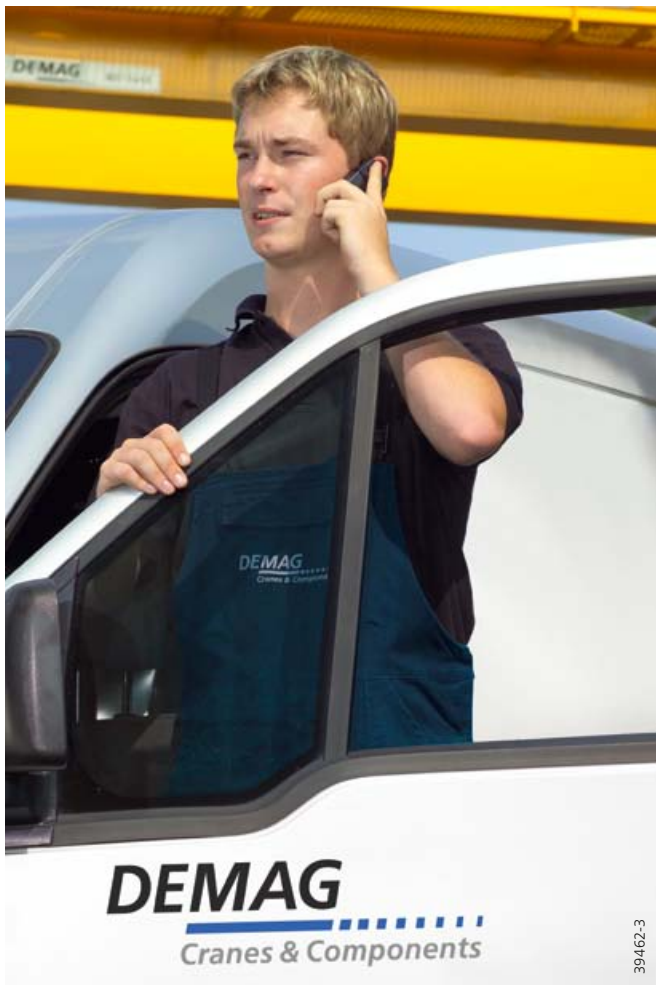

## Service systems: Demag IDAPSY

Demag Cranes & Components has developed an integrated service system for Demag DR rope hoists: Demag IDAPSY. IDAPSY stands for **I**nspection **D**iagnosis **A**pplication **S**ystem.

Service system with a wide range of benefits:

### ■ Transparency

By recording utilisation of the installation, Demag IDAPSY facilitates predictive and plannable service to ensure a high level of availability.

### ■ Analysis

Recorded data provides an excellent basis for analysis, e.g. the load spectrum recorder can be read out and error messages can be called up for maintenance or repair purposes.

### ■ Efficiency

Maintenance work carried out in good time ensures that your installation is in optimum condition and increases overall efficiency.

Demag IDAPSY enables service work to be carried out more quickly. This means that your hoist is also ready for operation again even more quickly if service work has to be carried out.

## Your individual service package

Demag Service and our Demag partners offer a comprehensive portfolio of services to ensure the lasting availability of your installation throughout its entire lifecycle:

- Recurring inspections according to relevant accident prevention regulations
- Inspection and maintenance
- Fault elimination both with and without on-call standby
- Service training for operators and maintenance engineers



40269

Crane system data can be read out for predictive and scheduled service.

# Technical data – selection criteria

The size of the hoist is determined by

- the load spectrum
- the average operating time
- the load capacity and
- the reeving arrangement

1. What are the operating conditions?
2. What is the specified safe working load?
3. To what height must the load be lifted?
4. What is the required lifting speed?
5. Do the loads need to be lifted and lowered with great accuracy?
6. Is horizontal load travel necessary?
7. How is the hoist to be controlled?

The group is determined from the operating time and load spectrum.

| Load spectrum              |            |      |      |     | Average operating time per working day (h) |            |            |            |   |
|----------------------------|------------|------|------|-----|--|------------|------------|------------|---|
| 1                          | Light      |      |      |     | 2-4  | 4-8        | 8-16       | over 16    |   |
| 2                          | Medium     |      |      |     | 1-2  | 2-4        | 4-8        | 8-16       |   |
| 3                          | Heavy      |      |      |     | 0.5-1                                      | 1-2        | 2-4        | 4-8        |   |
| 4                          | Very heavy |      |      |     | 0.25-0.5                                   | 0.5-1      | 1-2        | 2-4        |   |
| <b>Group of mechanisms</b> |            |      |      |     | <b>1 Am</b>                                | <b>2 m</b> | <b>3 m</b> | <b>4 m</b> |   |
| Reeving arrangement        |            |      |      |     | Size                                       |            |            |            |   |
| 1/1                        | 2/1        | 4/1  | 6/1  | 8/1 |  |            |            |            |   |
| 2/2                        | 4/2        | 8/2  |      |     |  |            |            |            |   |
| SWL (t)                    |            |      |      |     | Size                                       |            |            |            |   |
| 0.5                        | 1          | 2    | -    | -   | -  | -          | -          | -          | ■ |
| 0.63                       | 1.25       | 2.5  | -    | -   | -  | -          | -          | ■          | - |
| 0.8                        | 1.6        | 3.2  | -    | -   | DR 3                                       | -          | ■          | -          | ■ |
| 1                          | 2          | 4    | -    | -   | -  | -          | -          | ■          | - |
| 1.25                       | 2.5        | 5    | -    | -   | -  | -          | ■          | -          | - |
| 1.6                        | 3.2        | 6.3  | -    | -   | DR 5                                       | ■          | -          | -          | ■ |
| 2                          | 4          | 8    | 12.5 | -   | -  | -          | -          | ■          | - |
| 2.5                        | 5          | 10   | 16   | -   | -  | -          | ■          | -          | - |
| 3.2                        | 6.3        | 12.5 | 20   | 25  | DR 10                                      | ■          | -          | -          | ■ |
| 4                          | 8          | 16   | 25   | 32  | -  | -          | -          | ■          | - |
| 5                          | 10         | 20   | 32   | 40  | -  | -          | ■          | -          | - |
| 6.3                        | 12.5       | 25   | 40   | 50  | DR 20                                      | ■          | -          | -          | - |

## Example

|                      |                     |
|----------------------|---------------------|
| Load capacity        | 5 t                 |
| Load spectrum        | "medium" from table |
| Lifting speed        | 6 m/min             |
| Creep lifting speed  | 1 m/min             |
| Reeving              | 4/1                 |
| Average hook path    | 3 m                 |
| Cycles per hour      | 20                  |
| Working time per day | 8 hours             |

The average operating time per working day is estimated or calculated as follows:

$$\text{Operating time/day} = \frac{2 \cdot \text{av. hook path} \cdot \text{no. of cycles/h} \cdot \text{working time/day}}{60 \cdot \text{lifting speed}}$$

$$\text{Operating time/day} = \frac{2 \cdot 3 \cdot 20 \cdot 8}{60 \cdot 6} = 2.66 \text{ hours}$$

For the "medium" load spectrum and an average daily operating time of 2.66 hours, the table shows FEM group 2 m. For a load capacity of 5 t and 4/1 rope reeving, the table indicates hoist size DR 5 - 5.

## The load spectrum

(estimated in most cases) can be ascertained in accordance with the following definitions:

| 1 Light   | 2 Medium  | 3 Heavy  | 4 Very heavy  |
|---|---|--|---|
| Hoist units which are usually subject to very small loads and in exceptional cases only to maximum loads. | Hoist units which are usually subject to small loads but rather often to maximum loads. | Hoist units which are usually subject to medium loads but frequently to maximum loads. | Hoist units which are usually subject to maximum or almost maximum loads. |
|   |   |  |   |

## Selection table

| Range | SWL     | Hook path<br>m               | Lifting speed |         |          | Group of mechanisms<br>FEM/ISO | SWL  | Hook path<br>m      | Lifting speed |           |            |
|-------|---------|------------------------------|---------------|---------|----------|--------------------------------|------|---------------------|---------------|-----------|------------|
|       | t       |                              | m/min         |         |          |                                | t    |                     | m/min         |           |            |
| DR 3  | 2/1     |                              |               |         |          |                                | 4/1  |                     |               |           |            |
|       | 1.6     | 12<br>20                     | 12/2          | 18/3    | 1-25 *   | 2m / M5 **                     | 3.2  | 6<br>10             | 6/1           | 9/1.5     | 0.5-12.5 * |
|       | 1.25    |                              |               |         |          | 3m / M6 **                     | 2.5  |                     |               |           |            |
|       | 1       |                              |               |         |          | 4m / M7 **                     | 2    |                     |               |           |            |
| DR 5  | 2/1     |                              |               |         |          |                                | 4/1  |                     |               |           |            |
|       | 3.2     | 12<br>20<br>30               | 9/1.5         | 12/2    | 0.8-16 * | 1Am / M4 **                    | 6.3  | 6<br>10<br>15       | 4.5/0.8       | 6/1       | 0.4-8 *    |
|       | 2.5     |                              | 12/2          | 18/3    | 1-25 *   | 2m / M5 **                     | 5    |                     | 6/1           | 9/1.5     | 0.5-12.5 * |
|       | 2       |                              |               |         |          | 3m / M6 **                     | 4    |                     |               |           |            |
|       | 1.6     |                              |               |         |          | 4m / M7 **                     | 3.2  |                     |               |           |            |
|       | 4/2     |                              |               |         |          |                                |      |                     |               |           |            |
|       | 3.2     | 9.9<br>16.3                  | 9/1.5         | 12/2    | 0.8-16 * | 1Am / M4 **                    |      |                     |               |           |            |
|       | 2.5     |                              | 12/2          | 18/3    | 1-25 *   | 2m / M5 **                     |      |                     |               |           |            |
|       | 2       |                              |               |         |          | 3m / M6 **                     |      |                     |               |           |            |
|       | 1.6     |                              |               |         |          | 4m / M7 **                     |      |                     |               |           |            |
| DR 10 | 2/1     |                              |               |         |          |                                | 4/1  |                     |               |           |            |
|       | 6.3     | 12<br>20<br>30<br>40         | 8/1.4         | 0.4-9 * | 1-18 *   | 1Am / M4 **                    | 12.5 | 6<br>10<br>15<br>20 | 4/0.7         | 0.2-4.5 * | 0.5-9 *    |
|       | 5       |                              | 10/1.7        | 1-18 *  | 1-25 *   | 2m / M5 **                     | 10   |                     | 5/0.8         | 0.5-9 *   | 0.5-12.5 * |
|       | 4       |                              |               |         |          | 3m / M6 **                     | 8    |                     |               |           |            |
|       | 3.2     |                              |               |         |          | 4m / M7 **                     | 6.3  |                     |               |           |            |
|       | 4/2     |                              |               |         |          |                                | 6/1  |                     |               |           |            |
|       | 6.3     | 5.8<br>11.35<br>18.4<br>25.2 | 8/1.4         | 0.4-9 * | 1-18 *   | 1Am / M4 **                    |      | 6.7<br>13.3         | 2.7/0.4       | 0.3-6 *   | -          |
|       | 5       |                              | 10/1.7        | 1-18 *  | 1-25 *   | 2m / M5 **                     | 16   |                     |               |           |            |
|       | 4       |                              |               |         |          | 3m / M6 **                     | 12.5 |                     |               |           |            |
|       | 3.2     |                              |               |         |          | 4m / M7 **                     |      |                     |               |           |            |
| DR 20 | 2/1     |                              |               |         |          |                                | 4/1  |                     |               |           |            |
|       | 12.5    | 24<br>36<br>54               | 6/1           | 12/2    | 1-16 *   | 1Am / M4                       | 25   | 12<br>18<br>27      | 3/0.5<br>6/1  | 0.5-5 *   | 0.5-8 *    |
|       | 10      |                              |               |         |          | 2m / M5                        | 20   |                     |               |           |            |
|       | 8       |                              |               |         |          | 3m / M6                        | 16   |                     |               |           |            |
|       | 6.3     |                              |               |         |          | 4m / M7                        | 12.5 |                     |               |           |            |
|       | 4/2     |                              |               |         |          |                                | 6/1  |                     |               |           |            |
|       | 12.5    | 12.3<br>21.2<br>33.2         | 6/1           | 12/2    | 1-16 *   | 1Am / M4                       | 40   | 12<br>18<br>24.7    | 4/0.7         | 0.3-3.3 * | 0.3-5.3 *  |
|       | 10      |                              |               |         |          | 2m / M5                        | 32   |                     |               |           |            |
|       | 8       |                              |               |         |          | 3m / M6                        | 25   |                     |               |           |            |
|       | 6.3     |                              |               |         |          | 4m / M7                        | 20   |                     |               |           |            |
|       | 8/2     |                              |               |         |          |                                | 8/1  |                     |               |           |            |
|       | 25      | 10.3<br>16.3<br>23.4         | 3/0.5<br>6/1  | 0.5-5 * | 0.5-8 *  | 1Am / M4                       | 50   | 9<br>13.5<br>18.5   | 3/0.5         | 0.3-2.5 * | 0.2-4 *    |
|       | 20      |                              |               |         |          | 2m / M5                        | 40   |                     |               |           |            |
|       | 16      |                              |               |         |          | 3m / M6                        | 32   |                     |               |           |            |
| 12.5  | 4m / M7 |                              |               |         |          | 25                             |      |                     |               |           |            |

\* Loads weighing up to one third of the rated load are moved at 1.5 times the rated speed (Prohub)

\*\* Gearbox service life 20 % longer than the ISO/FEM full load service life

## The fast way to select your Demag DR rope hoist

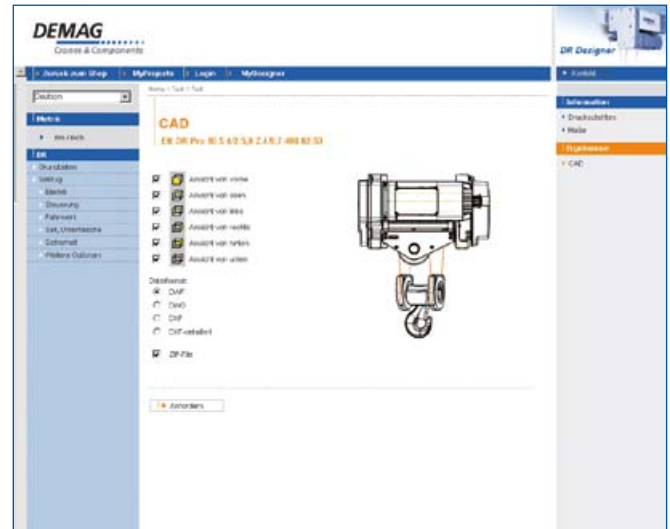
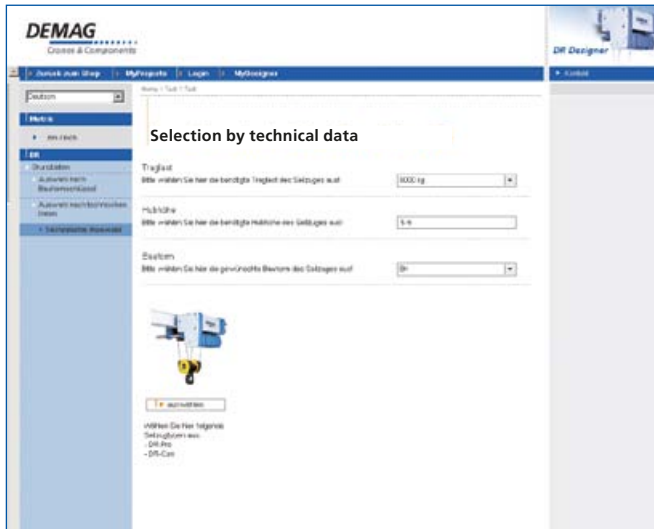

[www.dr.demag-designer.de](http://www.dr.demag-designer.de) is the address where all important facts and data on Demag DR rope hoists can be found. This information and planning platform provides you with a comprehensive product overview and contains all the data you need for project engineering. You can also download the CAD drawings of the entire Demag rope hoist range and integrate them into your design drawings.

Suitable hoists and accessories can be selected in this way.

The practical and intuitive user interface ensures that you find the right solution to meet your needs quickly and easily. You can then send us your specific enquiry at a click.

You can also use the fax form to send us your enquiry. In addition, experienced Demag engineers are ready to provide you with help and advice.

# Demag DR rope hoist project sheet

Demag Cranes & Components GmbH  
DR Rope Hoist Product Promotion  
Ruhrstraße 28

58300 Wetter/Germany

**Fax service: +49 (0) 2335 92-2339**

## Please send the quote to

\_\_\_\_\_  
Company

\_\_\_\_\_  
P.O. Box/street

\_\_\_\_\_  
Town/post code

\_\_\_\_\_  
Attention of

\_\_\_\_\_  
Phone

\_\_\_\_\_  
Fax

\_\_\_\_\_  
E-mail

SWL \_\_\_\_\_ kg

FEM Group (if known) \_\_\_\_\_ FEM

**If you do not know the FEM Group, please specify the type of application (e.g. workshop, production or similar)**

Actual operating time of the rope hoist per day \_\_\_\_\_ hours

Lifting height \_\_\_\_\_ m

Lifting speed \_\_\_\_\_ m/min

Variable lifting speed by means of an inverter  Yes  No

## Rope hoist and trolley design

Stationary rope hoist  Yes  No

Monorail hoist  Yes  No

Travel girder profile (flange width) \_\_\_\_\_ mm

Double-rail crab  Yes  No

Track gauge \_\_\_\_\_ mm

## Electrical equipment

Operating voltage \_\_\_\_\_ V \_\_\_\_\_ Hz

Option: remote control  Yes  No

## Special ambient conditions

(e.g. indoor or outdoor operation, ambient temperatures, operation in a galvanizing facility or similar)

\_\_\_\_\_  
\_\_\_\_\_  
\_\_\_\_\_  
\_\_\_\_\_  
\_\_\_\_\_

