



**Compact.  
Versatile.  
High Performance.**

**Demag DVR Rope Hoists**

**DEMAG**  
.....

# Compact. Versatile. High Performance.

The DVR rope hoist offers high efficiency and productivity. Thanks to its comprehensive options, the range includes solutions that can be configured to match a wide variety of crane and lifting requirements. From the standard version to high-performance equipment with smart safety functions, DVR rope hoists satisfy the demands of efficient lifting solutions.

## Compact

Low approach dimensions and reduced C-dimension: DVR hoists have a compact design and low dead-weight, providing the best possible utilization of the available space for crane applications.

## Versatile

DVR hoists offer tailored solutions on the basis of a single platform. Besides many possible model and reeving combinations, comprehensive basic equipment is already included as standard. Further hardware options and Smart features can turn a DVR rope hoist into a smart hoist that is well equipped to fulfill future needs.

## High Performance

Demag DVR rope hoists are available in five sizes with load capacities from 1 to 80 t.

## Configuration to Meet Your Needs

DVR hoist solutions can meet virtually any requirement: as foot mounted hoist solution as well as for optimized applications on single and double girder cranes. The range is completed by a basic hoist for plant engineering applications and rotating trolleys.



### F-DVR: Foot Mounted Rope Hoist

- For stationary applications or for special trolleys
- Can be used in 4 mounting positions, each with one rope lead-off direction
- Up to 80 tons

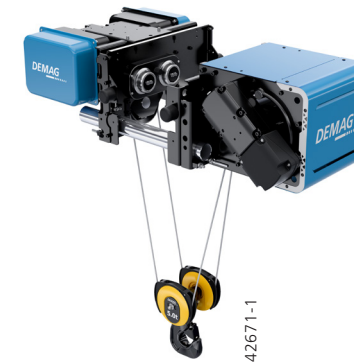

### EK-DVR: Low Headroom Monorail Hoist

- Optimized design with low headroom dimension for use on cranes and monorails
- Very short side approach dimensions
- Standard rubber bumpers
- Integrated drop stop
- Freely adjustable flange width 80 - 610 mm (3.15 - 24 in)



### EU-DVR: Standard Headroom Trolley

- For monorails with variable flange width 80 - 610 mm (3.15 - 24 in)
- Also available with an articulated trolley for traveling on curved tracks
- Precise positioning possible without hook travel
- For sizes DVR 3 to 20 with load capacities up to 40 t
- Optional patented track wheels for DVR 3 to 20, up to 20 t



### EZ-DVR: Double Girder Trolley

- Compact design thanks to narrow track gauges and wheel base dimensions
- Uniform distribution of wheel loads to all 4 wheels
- Individual adjustment thanks to different headroom dimensions and several mounting points for the hoist
- Direct drive arrangements
- Double girder trolley rail gauges:
  - Low: 1,400-2,000 mm (55.12"-78.74"), Medium: 1,200-4,200 mm (47.24"-165.35"), High: 900-2,400 mm (35.43"-95.49")

Size	Load capacity [t]																			
	1	1,25	1,6	2	2,5	3,2	4	5	6,3	8	10	12,5	16	20	32	40	50	63	80	
DVR 3	■	■	■	■	■	■														
DVR 5			■	■	■	■	■	■												
DVR 10					■	■	■	■	■	■	■	■	■	■						
DVR 20									■	■	■	■	■	■	■	■	■	■	■	
DVR 40																			■	
Types	F, EK, EU, EZ			■				F, EU, EZ				■				F, EZ				■

# DVR Rope Hoist: Overview

## Rope Drum/Rope Drive

- Large drum diameter with improved space utilization
- Low wear on ropes and return sheaves
- Minimum hook travel: Also due to limited inclined pull, loads can be moved and positioned safely and precisely
- Easy access to the upper return sheaves and anchorage points
- Rope drum encapsulated as standard with powder-coated metal surfaces

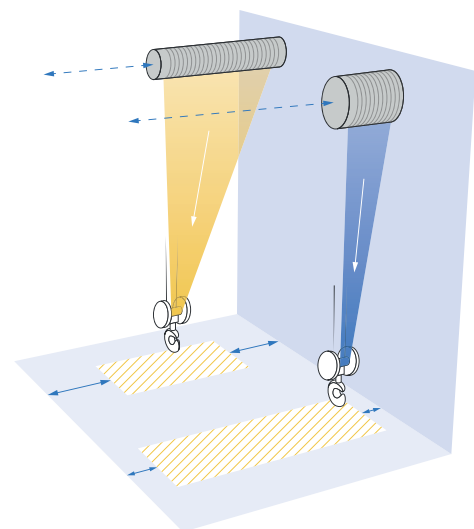

## Rope Guide

- Metal design
- The rope is guided reliably and with little wear on the drum for a longer rope service life



42679

## Hoist Gearbox

- Five different transmission ratios
- Compact and lightweight design
- Quiet and low-vibration operation thanks to ground helical gear wheels
- Lubricated for life

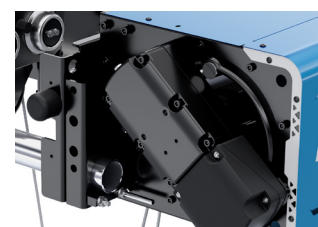

42671-1

## Hoist Motor

- Dual speed cylindrical-rotor motor, 6:1 ratio
- Standard pole-changing
- Optional inverter hoisting
- Motor outputs up to 35 kW
- Insulation class H
- Temperature rise F
- IP55 enclosure
- Standard fan cooling
- Standard temperature monitoring
- 60% duty factor (40/20)
- 300 starts per hour

## Hoist Brake

- Magnetic disc brake with high brake torque
- Fully enclosed design, IP55 enclosure
- Rated for a service life of 1 million switching cycles

## Lifting Limit Switches

- Installed and protected in the housing (no loss of headroom)
- 4 fully adjustable switching points
- High reliability, since there are no mechanical wearing parts
- Fast-to-slow cut-off in the upper position
- Phase monitoring
- Optional: hook-actuated limit switches

## Overload Protection

- Connection to electronic load management I (ELM I)
- Force measurement by strain gauge
- Optional: Electronic load management (ELM II) with high end monitoring

## Electric Enclosure

- Robust contactor control for reliable operation also in demanding environments
- Standard 3-phase supply: 380-415 V, 50 Hz (440-480 V, 60 Hz)
- Metal switchgear cabinet
- Easy to service: Hinged doors can be opened without special tools
- IP55 enclosure

## Travel Motor

- Inverter for variable travel speeds from 20 m/min (65 fpm)
- 40% CDF, FEM 2m (ISO M5)
- Lubricated for life
- Bi-metallic overheating protection
- Programmable frequency inverters

## Travel Wheels

- Two driven travel wheels, pressure rollers not needed
- GGG70 material

## Controller

### DST Pendant Controller (Optional):

- User-friendly design in various configurations with up to 9 control elements
- Low-fatigue operation thanks to ergonomic housing design
- Sloping pendant controller design permits operators to work in a natural, comfortable posture
- High operating reliability thanks to additional strain relief elements



19198



42683

## Bottom Block

- Ergonomic hook with handle (up to size DVR 10)
- DIN hook for sizes DVR 20 and 40
- Freely rotating 360°
- Additional safety thanks to hook safety catch

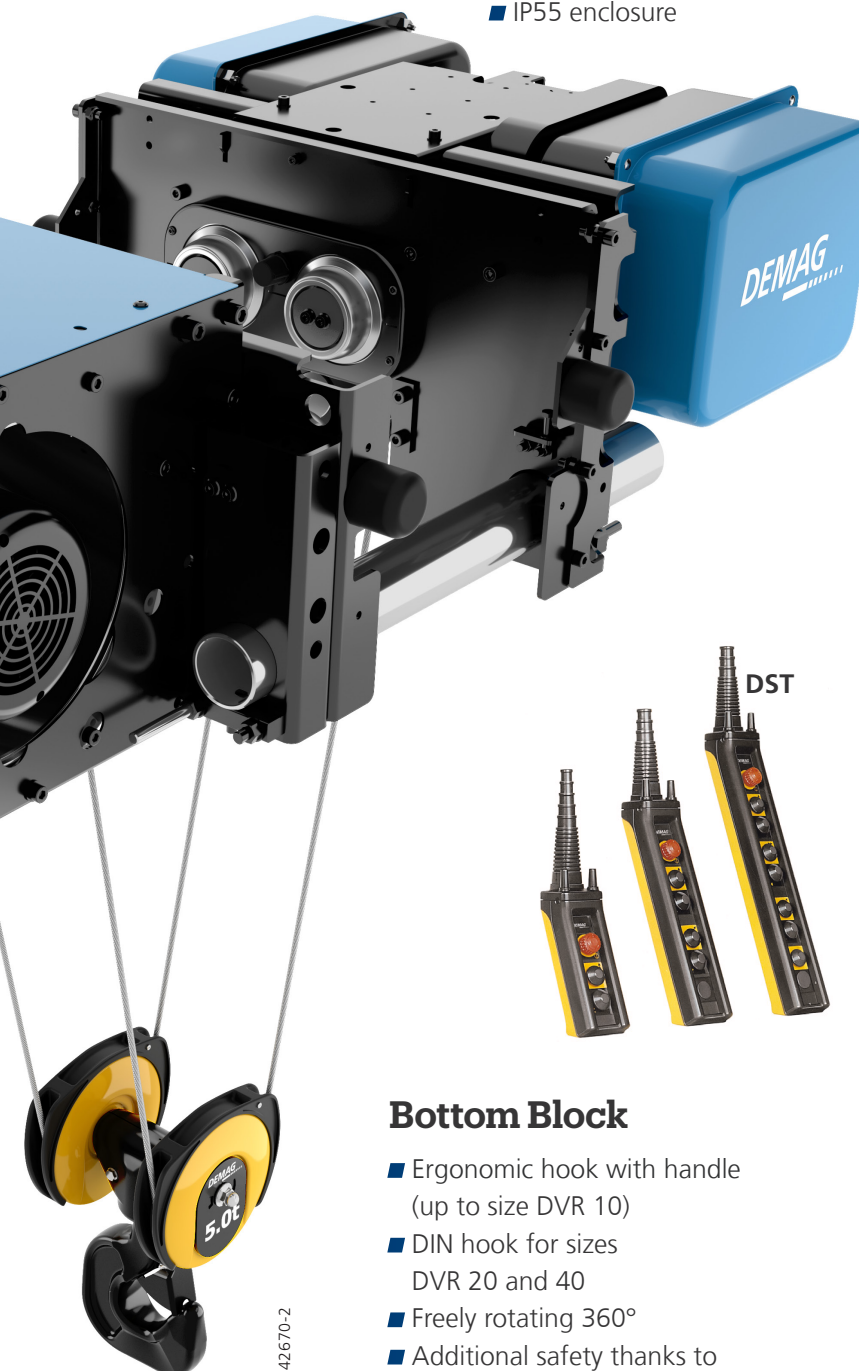

42670-2

# Configured to Meet Specific Application Needs

A variety of options are available to equip DVR rope hoists to meet application requirements.

DVR units can offer variable-speed drive solutions for lifting and travel motions at different technology levels. The benefits of their inverters are self-evident:

- Variable speeds: 1:10, 1:25, ESR 1:37
- Reduced wear: Gentle start-up/lifting reduces the load on the crane system
- Longer motor/brake service life
- Significant energy savings by up to 50%

Load-dependent lifting speed for higher productivity:

- High speed without load (up to 100%)
- Medium speed with partial load
- Precise speed with full load



## OWL

Compact unit for overload cut-off and status display for improved safety and predictive maintenance (ELM I).

- Overload protection for individual hoists
- Simple condition monitoring
- Number of switching operations
- Operating time
- Number of braking operations
- Number of control operations
- ON time
- Temperature index
- Number of events with overload
- Can be used for SWP calculation



## DMU

Monitoring unit with CAN bus functionalities for improved safety, extended service life of the brake and optimized maintenance intervals (ELM II). Determines training need for operators.

- Overload protection
- Monitoring for sudden load increase
- Temperature monitoring for motors
- SWP operating time counter
- Monitoring of the motor function
- Monitoring of the supply voltage phase
- Motor start/stop due to slow speed
- Multi-hoisting tandem (up to five units)
- Design limits (warnings)
- Optional remote monitoring modem
- Smart functions
- CAN bus functionalities

## Further Options for Tailored Configuration:

- Radio control
- Second hoist brake for DVR 3, 5, 10
- Drum brake for DVR 20 and 40
- DIN single or double hooks
- Rope pressure roller
- Horn
- Large load display
- Maintenance platform
- Stainless-steel switchgear cabinets
- Rain cover

# Smart Features

...turn your rope hoist into a smart hoist. They enable faster load cycle times, higher productivity and improved safety at the workplace.



## Anti-Sway Control

Prevents increased load sway by active counter-motions of the crane. Active system based on rope angle measurement to detect and dampen any existing load sway.



## Slack-Rope Prevention

Continuous monitoring of the rope tension: The hoist drive automatically switches off when the load has been lowered to its target position or if the hook is accidentally snagged. Reduces the risk of damage to the load, crane and surrounding area.



## Area-Specific Load Reduction

Areas can be defined which the traveling hoist may only enter if the load does not exceed a reference value. This reduces the load on the runway and building structure – especially when several cranes operate on one runway.



## Bypass Control

Areas to be blocked for the traveling hoist can be specified. In this way, you can safely bypass high parts of machinery or zones that are out of bounds.



## Tandem Control

Loads can be safely transported by two DVR rope hoists – via a single control unit.



## Follow Me

Makes lifting operations much faster because the crane can be moved above the load by simply guiding the hook by hand. (Recommended for cranes up to 10 t).



## Hook Centering

Makes lifting operations much faster because the crane can be moved Positions the crane hook automatically directly over the load. The benefits: faster load cycle times and ease of operation.



## Smart Tandem Control

Two cranes with up to four rope hoists can also be synchronized.



# Demag DVR: At a Glance



42673

**F-DVR: Foot Mounted Rope Hoist**

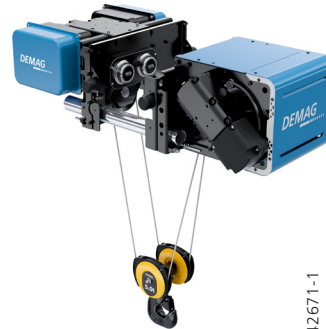

42671-1

**EK-DVR: Low Headroom Monorail Hoist**



42675

**EU-DVR: Standard Headroom Trolley**



42677

**EZ-DVR: Double Girder Trolley**

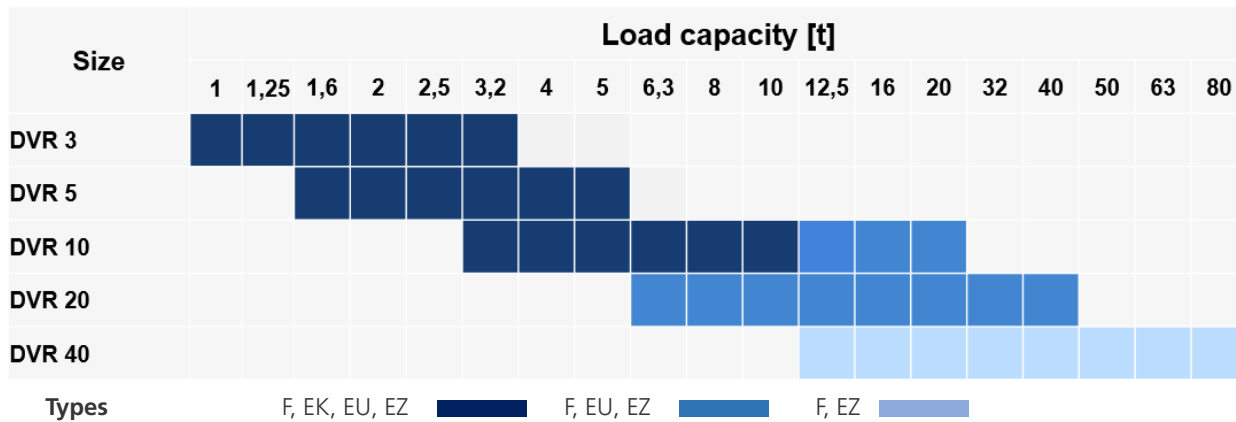

**DEMAG CRANES AND COMPONENTS CORP.**

6675 Parkland Blvd., Suite 200  
Cleveland, Ohio 44139  
United States

E demaginfo.us@demagcranes.com

T +1 440 248 2400

[www.demagcranes.us](http://www.demagcranes.us)



0323 EN\_EN/ 213 820 44 701 IS 813  
No liability for errors or omissions. Subject to change.  
Printed in USA D/20230301/PDF